

(Subject to Renew January 1st, 2021 or next code cycle)**EVALUATION SUBJECT: PACKAGED UNITS****TER-19-8163.2****REPORT HOLDER:**NORTEK GLOBAL HVAC
8000 PHOENIX PARKWAY
O'FALLON, MO 63368 USA
(800) 422-4328 | NORTEK.COM**SCOPE OF EVALUATION** (compliance with the following codes):**THIS IS A STRUCTURAL (WIND) PERFORMANCE EVALUATION ONLY. NO ELECTRICAL OR TEMPERATURE PERFORMANCE RATINGS OR CERTIFICATIONS ARE OFFERED OR IMPLIED HEREIN.**

This Product Evaluation Report is being issued in accordance with the requirements of the **Florida Building Code Sixth Edition (2017)** per FBC Section 104.11.1, FMC 301.15, FBC Building Ch. 16, ASCE-7-10, FBC Existing Building sections 707.1, 707.2, FBC Building 1522.2, and FBC Residential M1202.1, M1301.1, FS 471.025, including Broward County Administrative Provisions 107.3.4. The product noted on this report has been tested and/or evaluated as summarized herein.

IN ACCORDANCE WITH THESE CODES EACH OF THESE REPORTS MUST BEAR THE ORIGINAL SIGNATURE & RAISED SEAL OF THE EVALUATING ENGINEER.**SUBSTANTIATING DATA:****• Product Evaluation Documents**

Substantiating documentation has been submitted to support this TER and is summarized in the sections that follow.

• Structural Engineering Calculations

Structural engineering calculations have been prepared which evaluate the product based on comparative and/or rational analysis to qualify the following design criteria:

- Maximum allowable unit panel wind pressure connection integrity
- Maximum allowable uplift, sliding, & overturning moment for ground and roof applications

Calculation summary for this TER is provided in the force's summary table. No 33% increase in allowable stress has been used in the design of this product. Microsoft Excel was used to carry out the calculations present in this report.

INSTALLATION:

The product(s) listed in this report shall be installed in strict compliance with this TER & manufacturer-provided model specifications.

The product components shall be of the material specified in the manufacturer-provided product specifications. All screws must be installed in accordance with the applicable provisions & anchor manufacturer's published installation instructions.

LIMITATIONS & CONDITIONS OF USE:

Use of this product shall be in strict accordance with this TER as noted herein. See final page for complete limitations and conditions of use.

OPTIONS:

This evaluation is valid for all NORTEK models shown on the last page.

FINISH:

Baked enamel.

NOTE: GRAPHICAL DEPICTIONS IN THIS REPORT ARE FOR ILLUSTRATIVE PURPOSES ONLY AND MAY DIFFER IN APPEARANCE**UNIT CASING MATERIAL:**

20ga galvanized metal sheet ASTM A653 steel for removable top panel. 18ga galvanized metal sheet ASTM A653 steel for base pan. Cabinets A, B, & C with 22ga galvanized metal sheet ASTM A653 for side protector panels A, B, D, 20ga galvanized metal sheet ASTM A653 for side protector panels C,G, 18ga galvanized metal sheet ASTM A653 for side protector panels E, F. Cabinet D, E, 22ga galvanized metal sheet ASTM A653 for side protector panels A, B, D and 20ga galvanized metal sheet ASTM A653 for side protector panels C; secured with SAE 1022 #10 sheet metal screws into top and base pan.

INSTALLATION:

Shall follow manufacturer specifications as well as the information provided herein.

STRUCTURAL PERFORMANCE:

Models referenced herein are subject to the following design limitations: ASCE-710 Exposure Categories C

Up to and including 175mph (Vult) for up to See Page 2 MRH**. HVHZ***

Up to 200mph (Vult). Non-HVHZ*** Ground EXP D

Ground or Roof Application per installation instructions

Mean Roof Height *High Velocity Hurricane Zone

Maximum Rated Wind Pressure:

118psf Lateral, 93psf Uplift (ASD)**ABOUT THIS DOCUMENT:**

ENGINEER CERTIFIED ORIGINALS, VARIATIONS & HELP CAN BE FOUND BY VISITING THE WEB ADDRESS FOUND HERE BY VISITING THE WEB ADDRESS OR SCANNING THE QR CODE TO THE RIGHT >

VISIT ENGINEERINGEXPRESS.COM/STORE FOR MORE REPORTS ECALC.IO/1981632**ORIGINAL SIGNATURE AND RAISED SEAL
OR DIGITAL SEAL REQUIRED TO BE VALID PER CODE:**

February 1, 2020

Frank L. Bennardo, P.E., SECB

 Signed by If Checked:

ENGINEERING EXPRESS®

GORDON DiBATTISTO, PE

FL PE #0046549

FLCA #9885

FL PE #82328

NOTICE: IF THIS PAGE DOES NOT CONTAIN AN ORIGINAL SIGNATURE & ENGINEER SEAL: IF THERE IS A DIGITAL SIGNATURE ON PAGE 1, THIS DOCUMENT IS PART OF A DIGITALLY SIGNED FILE, SHALL REMAIN IN DIGITAL FORMAT & PRINTED COPIES OF THIS DOCUMENT ARE NOT CONSIDERED SIGNED AND SEALED. IF THERE IS NO DIGITAL SIGNATURE ON PAGE 1 OR THIS PAGE DOES NOT CONTAIN AN ENGINEER'S ORIGINAL SIGNATURE & SEAL, THIS DOCUMENT IS A COPY/DRAFT.

SECTION 2 PRODUCT INSTALLATION

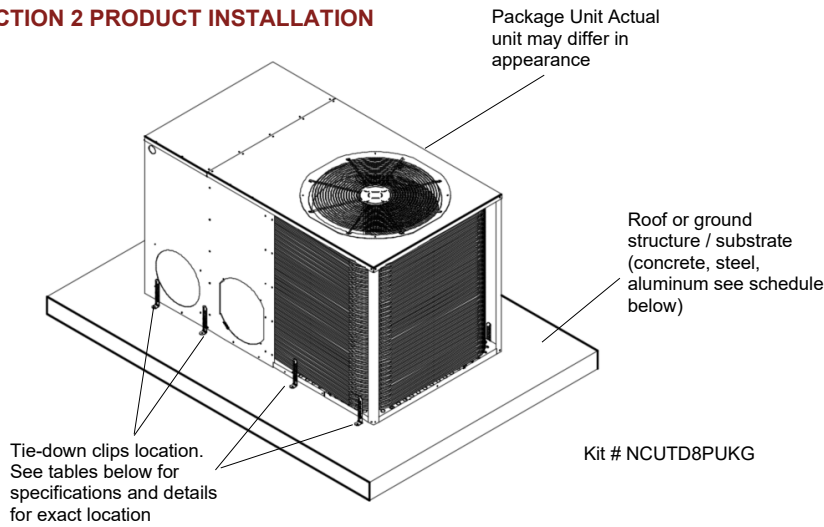

TIE-DOWN (GROUND APPLICATION)

Miami Tech CUTD 1" wide and 8" long min ASTM A653 galvanized steel 0.07" thick for all cabinets tied down at ground; fasten clip to host structure using anchor from Anchor Schedule to Host Structure Table, (2) #10-16 x 1/2" Gr2 min self-drilling screw to fasten clip to unit for cabinet D & E, (4) #10-16 x 1/2" Gr2 min self-drilling screw to fasten clip to unit for cabinet A, B & C.

TIE-DOWN (ROOF APPLICATION)

Miami Tech CUTD 1" wide and 8" long min ASTM A653 galvanized steel 0.07" thick for cabinets D & E tied down to aluminum stand; fasten clip to host structure using anchor from Anchor Schedule to Host Structure Table, (2) #10-16 x 1/2" Gr2 min self-drilling screw to fasten clip to unit. See detail page

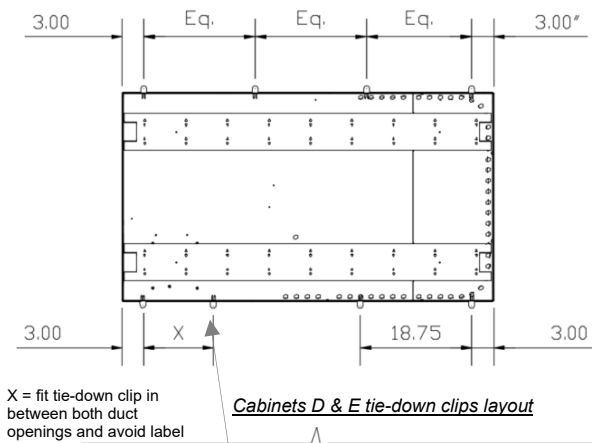
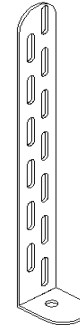

Cabinets D & E tie-down clips layout

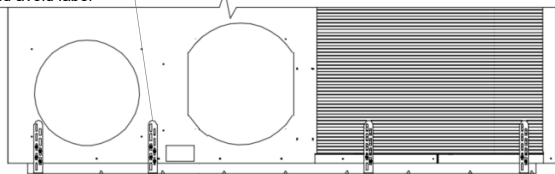

Cabinets D & E tie-down clips elevation

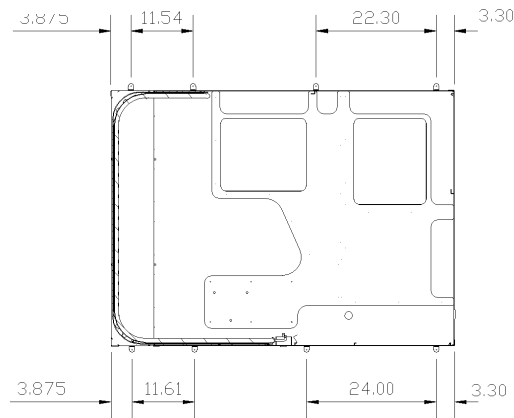

Cabinets A, B & C tie-down clips layout

TIE-DOWN STRAP & CLIP SCHEDULE

Cabinet	Ground or Roof Height*	Tie-down Strap	Strap Width & Thickness	Tie-down Clips to Ground	Tie-down Anchor to Curb	Tie-down Clip to Stand
Cabinet B	Up to 200' (250')	3	1.5" 22ga	NA	10S-13L	8S - 0L
Cabinet C						
Cabinet D	Ground	NA	NA	0S - 4L	NA	NA
Cabinet E	Up to 200' (250')	3	1.5" 22ga	NA	NA	8S - 0L

- See tables on last page for cabinet classification.
- Tie-down Clip/ Anchor Designation: 1S= 1 clip per short side, 3L= 3 clips per long side.

Tie-down Strap & Clip Notes:

1. Minimum edge distance 3" from the unit corners.
2. Use # of tie-down straps per schedule.
3. Tie-down strap shall be wrapped and tightened to a snug fit around the unit and attached to the unit base rail, as shown in the detail page.
4. Neoprene pad shall be placed between the strap and the cabinet to prevent distortion or any damage (optional).
5. Tie-down clips shall be above layout or as shown in details.

ANCHOR TO HOST STRUCTURE SCHEDULE

Cabinet	Ground or Roof Height*	Anchor Type			
		Concrete 3,000 Psi	A653 Steel Curb	1/8" Min A36 Steel	1/8" Min 6061-T6 Aluminum
Cabinet A	Ground	A	NA	NA	NA
Cabinet B	Up to 200' (250')	NA	B	C	C
Cabinet C					
Cabinet D	Ground	A	NA	NA	NA
Cabinet E	Up to 200' (250')	NA	NA	C	C

*The value shown in parentheses indicates the allowable roof height in 170mph conditions. i.e. 200' (250') indicates an allowable roof height of 200' for 175mph or 250' for 170mph Vult.

Anchor Types to Host Structure:

- A. - 1/4" ELCO ULTRACON Anchor embedded 1 3/4" in 3,000 psi concrete. 2 1/2" from edge minimum and 4" spacing.
- B. - 3/8" Self-drilling screw Grade 5 screw minimum 5/8" from edges.
- C. - 1/4" SS410 Thru-bolt minimum 5/8" from edges, with 1.0" OD washer top & bottom and nut.
- NA. - No anchors apply.

IN ALL CONDITIONS IT IS THE RESPONSIBILITY OF THE PERMIT HOLDER TO ENSURE THE HOST STRUCTURE IS CAPABLE OF WITHSTANDING THE RATED GRAVITY, LATERAL, AND UPLIFT FORCES BY SITE-SPECIFIC DESIGN. NO WARRANTY OF ANY KIND, EXPRESSED OR IMPLIED, IS OFFERED BY ENGINEERING EXPRESS AS TO THE INTEGRITY OF THE HOST STRUCTURE TO CARRY DESIGN FORCE LOADS INCURRED BY THIS UNIT.

TIE-DOWN STRAP AND CLIP LAYOUT

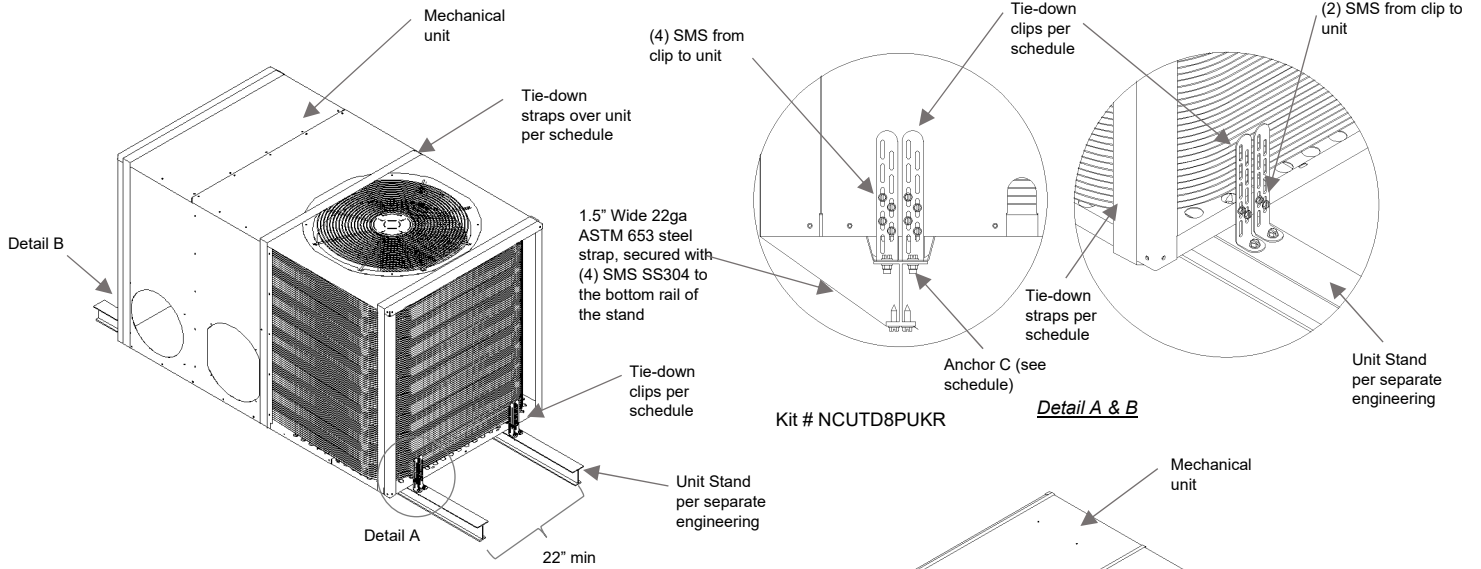

Cabinets D & E tie-down clips & strap isometric

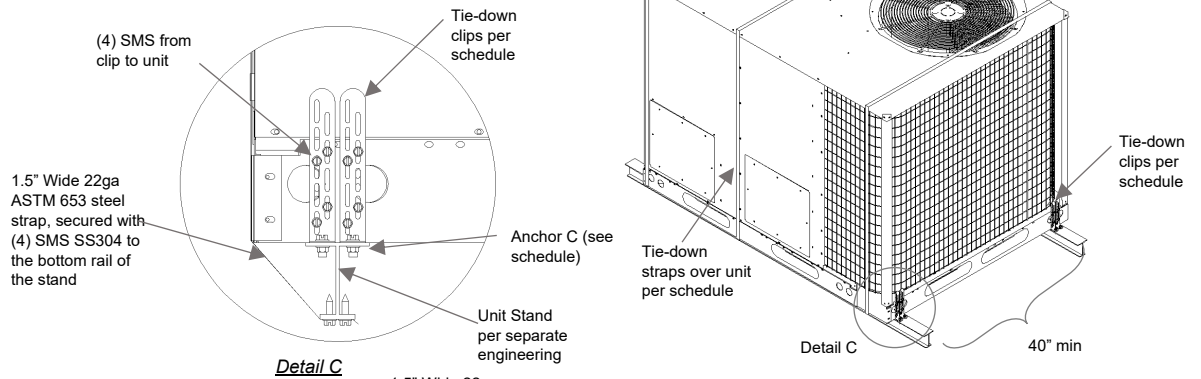

Cabinets A, B & C tie-down clips & strap isometric

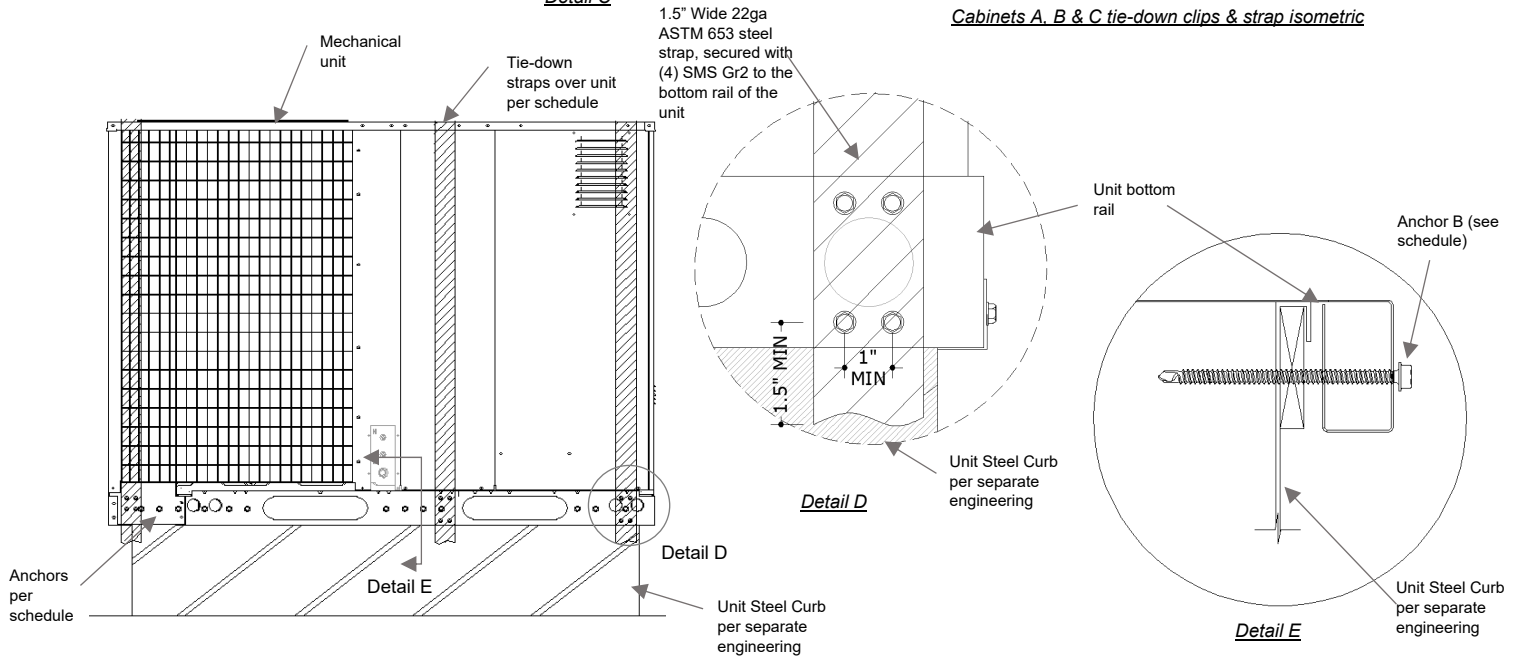

Cabinets A, B & C tie-down Curb & strap elevation

SECTION 3 SUPPORTING CALCULATIONS & SUMMARY

FORCES SUMMARY

Cabinet	Ground or Roof Height*	Lateral Pressure (Psf)	Uplift Pressure (Psf)	Max Large Side Force	Max Large Side Overturn (lbs-in)	Max Large Side Tension (lbs)	Max short Side Force (lbs)	Max Short Side Overturn (lbs-in)	Max Short Side Tension (lbs)	Max Uplift Force (lbs)
Cabinet A Cabinet B Cabinet C	Ground	50.2	41.2	1041.5	49475.4	1041.6	777.9	51753.0	813.7	1052.6
	Up to 200' (250')	118.3	93.4	2455.4	104231.2	2194.3	1833.8	105395.0	1657.2	1959.1
Cabinet D Cabinet E	Ground	50.2	41.2	838.5	29461.1	841.7	465.9	33098.9	525.4	768.3
	Up to 200' (250')	118.3	93.4	1976.9	62781.8	1793.8	1098.3	66019.6	1047.9	1429.9

PANEL INTEGRITY SUMMARY

Cabinet	Ground or Roof Height	Panel Name	Rqrd Wind Pressure (lb/ft²)	Force on Panel (lbs)	Add'l Screw Qty Required (pcs)	Add'l screws required for original cabinet	Cabinet	Force on Panel (lbs)	Add'l Screw Qty Required (pcs)	Add'l screws required for original cabinet	
Cabinet A Cabinet B Cabinet C	Ground	TOP PANEL	41.19	864.13	0	Yes	Cabinet D	453.67	0	No	
		PANEL A	50.17	330.79	0			453.76	0		
		PANEL B	50.17	359.44	0			266.18	0		
		PANEL C	50.17	268.99	0			139.71	0		
		PANEL D	50.17	412.76	0			309.53	0		
		PANEL E	50.17	258.75	1			169.94	0		
		PANEL F	50.17	161.28	0			-	-		
	Up to 200' (250')	PANEL G	50.17	79.84	0	-	-	Cabinet E	0.00	0	Yes
		TOP PANEL	93.38	1959.11	0	1069.84	0				
		PANEL A	118.29	779.90	1	627.57	1				
		PANEL B	118.29	847.46	2	329.38	0				
		PANEL C	118.29	634.19	1	729.78	1				
		PANEL D	118.29	973.15	1	385.28	0				
		PANEL E	118.29	610.06	2	-	-				
PANEL F	118.29	380.26	0	-	-						
		PANEL G	118.29	188.25	0	-	-				

Note:

1. Calculations performed according to the information provided by the client. Cabinets were assumed solid (0% porosity) for shear and tension calculation purposes.
2. Screw quantities were checked to reinforce unit panels as needed. They shall be spaced evenly throughout the panel bottom part, validating that the screw joins the panel with the supporting element. Screw sizes, quantities on panel, and panel characteristics are according to client's description.
3. Additional screw shall be at least #10 Gr 2.
4. Installer shall insulate dissimilar metals.

UNIT MODELS DIMENSIONS AND PANEL LOCATION

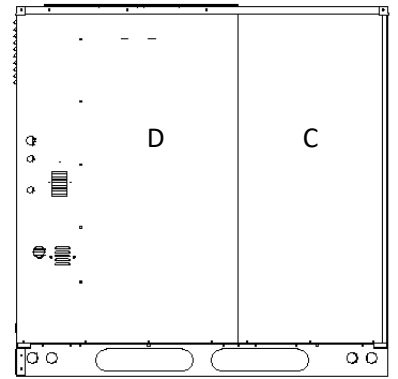
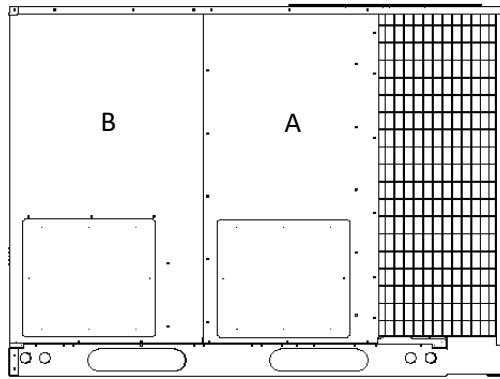
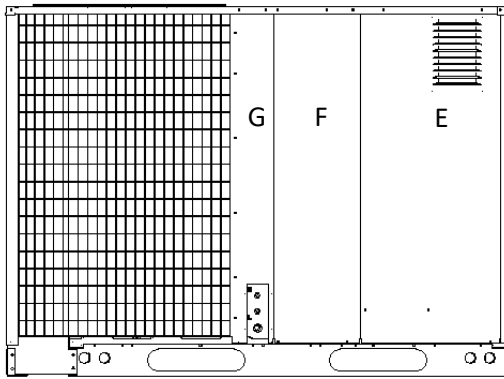

Cabinets A, B & C

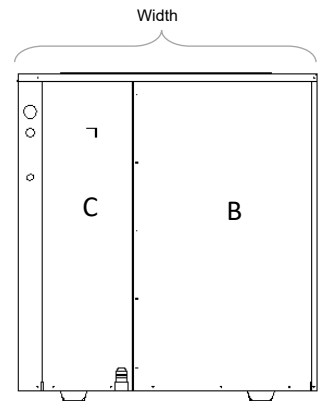
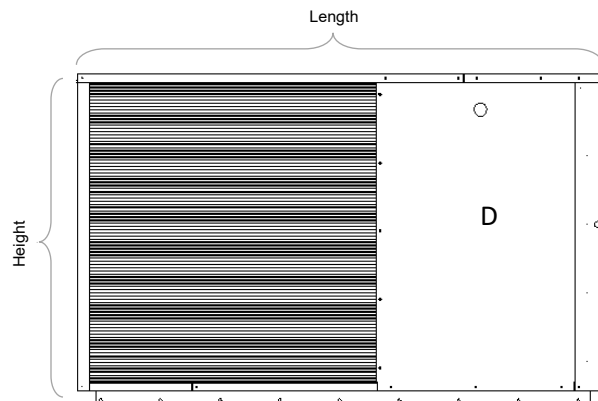
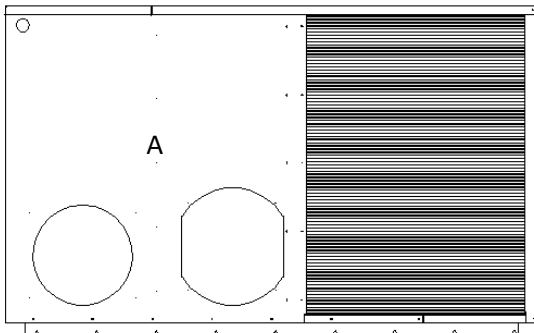

Cabinets D & E

Model Number	Weight (in)	Length (in)	Width (in)	Height (in)	Cabinet
P7RE-018K	226	49	35	22.2	D
P7RE-024K	230	49	35	22.2	D
P7RE-030K	236	49	35	22.2	D
P7RE-036K	230	49	35	22.2	D
P7RE-042K	283	49	35	30.2	D
P7RE-048K	286	49	35	30.2	D
P7RE-X60KA	309	49	35	34.2	D
P7RF-X24K	243	49	35	30.2	D
P7RF-X36K	255	49	35	30.2	D
P7RF-X48K	315	49	35	38.2	E
P7RF-X60K	355	63	35	38.2	E
PPA3RFX24K	264	49	35	30.2	D
PPA3RFX36K	276	49	35	30.2	D
PPA3RFX48K	338	49	35	38.2	E
PPA3RFX60K	415	63	35	38.2	E
PPH3RFX24K	259	49	35	30.2	D
PPH3RFX36KA	294	49	35	38.2	E
PPH3RFX48K	354	63	35	38.2	E
PPH3RFX60K	361	63	35	38.2	E
Q7RE-024K	263	49	35	30.2	D
Q7RE-030K	267	49	35	30.2	D
Q7RE-036K	263	49	35	30.2	D
Q7RE-042K	274	49	35	30.2	D
Q7RE-048K	330	63	35	38.2	E
Q7RE-060K	359	63	35	38.2	E
Q7RF-X24K	259	49	35	30.2	D
Q7RF-X36KA	294	49	35	30.2	D
Q7RF-X48K	354	63	35	30.2	D
Q7RF-X60K	361	63	35	30.2	D
RP7RE-018K	226	49	35	22.2	D
RP7RE-024K	230	49	35	22.2	D

Model Number	Weight (in)	Length (in)	Width (in)	Height (in)	Cabinet
RP7RE-030K	236	49	35	22.2	D
RP7RE-036K	230	49	35	22.2	D
RP7RE-042K	283	49	35	30.2	D
RP7RE-048K	286	49	35	30.2	D
RP7RE-X60KA	309	49	35	34.2	D
RP7RF-X24K	243	49	35	30.2	D
RP7RF-X36K	255	49	35	30.2	D
RP7RF-X48K	315	49	35	38.2	E
RP7RF-X60K	355	63	35	38.2	E
RQ7RE-024K	263	49	35	30.2	D
RQ7RE-030K	267	49	35	30.2	D
RQ7RE-036K	263	49	35	30.2	D
RQ7RE-042K	274	49	35	30.2	D
RQ7RE-048K	330	63	35	38.2	E
RQ7RE-060K	359	63	35	38.2	E
VP7RE-024K	230	49	35	22.2	D
VP7RE-030K	236	49	35	22.2	D
VP7RE-036K	230	49	35	22.2	D
VP7RE-042K	283	49	35	30.2	D
VP7RE-048K	286	49	35	30.2	D
VP7RE-X60KA	309	49	35	34.2	D
VQ7RE-024K	263	49	35	30.2	D
VQ7RE-030K	267	49	35	30.2	D
VQ7RE-036K	263	49	35	30.2	D
VQ7RE-042K	274	49	35	30.2	D
VQ7RE-048K	330	63	35	38.2	E
VQ7RE-060K	359	63	35	38.2	E

Model Number	Weight (lbs)	Length (in)	Width (in)	Height (in)	Cabinet
DF6SF-X24K080CB	480	47.5	55.8	39	A
DF6SF-X36K100CB	480	47.5	55.8	43	B
DF6SF-X48K120CB	612	47.5	55.8	43	B
DF6SF-X60K120CB	612	47.5	63.6	47	C
P8SE-X36C	405	47.5	55.8	39	A
P8SE-X36D	415	47.5	55.8	39	A
P8SE-X36K	405	47.5	55.8	39	A
P8SE-X48C	480	47.5	55.8	39	A
P8SE-X48D	405	47.5	55.8	39	A
P8SE-X48K	480	47.5	55.8	39	A
P8SE-X60C	415	47.5	55.8	43	B
P8SE-X60D	480	47.5	55.8	43	B
P8SE-X60K	415	47.5	55.8	43	B
PDF2SFX24K080CB	480	47.5	55.8	39	A
PDF2SFX36K100CB	480	47.5	55.8	43	B
PDF2SFX48K120CB	612	47.5	55.8	43	B
PDF2SFX60K120CB	612	47.5	63.6	47	C
PPA3SE-X36K	415	47.5	55.8	39	A
PPA3SE-X48K	405	47.5	55.8	39	A
PPA3SE-X60K	480	47.5	55.8	43	B
PPG2GFX24K080XA	460	47.5	55.8	39	A
PPG2GFX36K100XA	480	47.5	55.8	39	A
PPG2GFX48K120XA	609	47.5	55.8	47	B
PPG2GFX60K120XA	659	47.5	63.6	47	C
PPG3GE024K045C	397	47.5	55.8	35	A
PPG3GE024K072C	405	47.5	55.8	35	A
PPG3GE030K045C	398	47.5	55.8	35	A
PPH2SEX24K	400	47.5	55.8	39	A
PPH2SEX30K	400	47.5	55.8	39	A
PPH2SEX36K	400	47.5	55.8	39	A
PPH2SEX42K	507	47.5	55.8	43	B
PPH2SEX48K	507	47.5	55.8	43	B
PPH2SEX60K	508	47.5	55.8	43	B
Q6SE-X24K	400	47.5	55.8	39	A
Q6SE-X30K	400	47.5	55.8	39	A
Q6SE-X36K	400	47.5	55.8	39	A
Q6SE-X42K	507	47.5	55.8	43	B
Q6SE-X48K	507	47.5	55.8	43	B
Q6SE-X60K	508	47.5	55.8	43	B
R6GF-X24K080XB	460	47.5	55.8	39	A
R6GF-X36K100XB	480	47.5	55.8	39	A
R6GF-X48K120XB	609	47.5	55.8	47	B
R6GF-X60K120XB	659	47.5	63.6	47	C
VR8GE-024K045C	397	47.5	55.8	35	A
VR8GE-024K072C	405	47.5	55.8	35	A
VR8GE-030K045C	398	47.5	55.8	35	A
VR8GE-024K045X	397	47.5	55.8	35	A
VR8GE-030K045X	398	47.5	55.8	35	A
VR8GE-030K072C	406	47.5	55.8	35	A
VR8GE-036K072C	403	47.5	55.8	35	A
VR8GE-036K072X	403	47.5	55.8	35	A
VR8GE-036K096C	411	47.5	55.8	35	A
VR8GE-042K072C	435	47.5	55.8	39	A
VR8GE-042K096C	443	47.5	55.8	39	A
VR8GE-042K096X	443	47.5	55.8	39	A
VR8GE-048K096C	453	47.5	55.8	39	A
VR8GE-048K096X	453	47.5	55.8	39	A
VR8GE-048K120C	461	47.5	55.8	39	A
VR8GE-X60K096C	472	47.5	55.8	43	B
VR8GE-X60K096X	472	47.5	55.8	43	B
VR8GE-X60K120C	480	47.5	55.8	43	B

Model Number	Weight (lbs)	Length (in)	Width (in)	Height (in)	Cabinet
PPG2GIE24K080X	460	47.5	55.8	39	A
PPG2GIE36K100X	480	47.5	55.8	39	A
PPG2GIE48K120X	609	47.5	55.8	47	B
PPG2GIE60K120X	659	47.5	63.6	47	C
PPG3GE024K045X	397	47.5	55.8	35	A
PPG3GE030K045X	398	47.5	55.8	35	A
PPG3GE030K072C	406	47.5	55.8	35	A
PPG3GE036K072C	403	47.5	55.8	35	A
PPG3GE036K072X	403	47.5	55.8	35	A
PPG3GE036K096C	411	47.5	55.8	35	A
PPG3GE042K072C	435	47.5	55.8	39	A
PPG3GE042K096C	443	47.5	55.8	39	A
PPG3GE042K096X	443	47.5	55.8	39	A
PPG3GE048K096C	453	47.5	55.8	39	A
PPG3GE048K096X	453	47.5	55.8	39	A
PPG3GE048K120C	461	47.5	55.8	39	A
PPG3GEX60K096C	472	47.5	55.8	43	B
PPG3GEX60K096X	472	47.5	55.8	43	B
PPG3GEX60K120C	480	47.5	55.8	43	B
PPG3HEX24K060XA	380	47.5	55.8	35	A
PPG3HEX30K060XA	384	47.5	55.8	35	A
PPG3HEX36K080XA	391	47.5	55.8	35	A
PPG3HEX42K080XA	407	47.5	55.8	39	A
PPG3HEX48K096XA	455	47.5	55.8	43	B
PPG3HEX60K096XA	485	47.5	55.8	47	B
R6GI-E24K080X	460	47.5	55.8	39	A
R6GI-E36K100X	480	47.5	55.8	39	A
R6GI-E48K120X	609	47.5	55.8	47	B
R6GI-E60K120X	659	47.5	63.6	47	C
R8GE-024K045C1	397	47.5	55.8	35	A
R8GE-024K072C1	405	47.5	55.8	35	A
R8GE-030K045C1	398	47.5	55.8	35	A
R8GE-030K045X1	398	47.5	55.8	35	A
R8GE-030K072C1	406	47.5	55.8	35	A
R8GE-036K072C1	403	47.5	55.8	35	A
R8GE-036K072X1	403	47.5	55.8	35	A
R8GE-036K096C1	411	47.5	55.8	35	A
R8GE-042K072C1	435	47.5	55.8	39	A
R8GE-042K096C1	443	47.5	55.8	39	A
R8GE-042K096X1	443	47.5	55.8	39	A
R8GE-048K096C1	453	47.5	55.8	39	A
R8GE-048K096X1	453	47.5	55.8	39	A
R8GE-048K120C1	461	47.5	55.8	39	A
R8GE-X24K045X1	397	47.5	55.8	35	A
R8GE-X60K096C1	472	47.5	55.8	43	B
R8GE-X60K096X1	472	47.5	55.8	43	B
R8GE-X60K120C1	480	47.5	55.8	43	B
R8HE-X24K060XA	380	47.5	55.8	35	A
R8HE-X30K060XA	384	47.5	55.8	35	A
R8HE-X36C080X	391	47.5	55.8	35	A
R8HE-X36D080X	408	47.5	55.8	35	A
R8HE-X36K080XA	391	47.5	55.8	35	A
R8HE-X42K080XA	407	47.5	55.8	39	A
R8HE-X48C096X	455	47.5	55.8	43	B
R8HE-X48D096X	472	47.5	55.8	43	B
R8HE-X48K096XA	455	47.5	55.8	43	B
R8HE-X60C096X	485	47.5	55.8	47	B
R8HE-X60D096X	502	47.5	55.8	47	A
R8HE-X60K096XA	485	47.5	55.8	47	B

LIMITATIONS & CONDITIONS OF USE:

Use of this product shall be in strict accordance with this TER as noted herein.

The supporting host structure shall be designed to resist all superimposed loads as determined by others on a site specific basis as may be required by the Authority Having Jurisdiction. Host structure conditions which are not accounted for in this product's respective anchor schedule shall be designed on a site-specific basis by a registered professional engineer. No evaluation is offered for the host supporting structure by use of this document; Adjustment factors noted herein and the applicable codes must be considered, where applicable. All supporting components which are permanently installed shall be protected against corrosion, contamination, and other such damage at all times. Fasteners must penetrate the supporting members such that the full length of the threaded portion is embedded within the main member. All anchors, screws, straps, clips, and attachment part can be substituted for equivalent parts, as long as the capacities of the equivalent parts are equal or stronger.

This evaluation does not offer any evaluation to meet large missile impact debris requirements which typically are not required for this type of product.

All of the wind resisting exterior panels, individually meet or exceed their capacity to resist the design wind loads as stated in the calculations as required by the FBC. Due to the indeterminate nature of these units, distortion and deflection cannot be accurately evaluated, but with diaphragm action of external components and internal stiffeners, the base unit has the capacity to withstand these forces with individual external parts being contained. Yearly inspections, during equipment maintenance or after a named storm; all screws, cabinet components, clips, anchor, bolts, straps and cables are to be verified by the A/C contractor. All damaged cabinet components, loose, corroded, broken screws or anchor bolts shall be replaced to ensure structural integrity for hurricane wind forces.